

Assembly Instructions

To Suit: Chrysler Big Block - Three bolt

1 Standard Timing

Using keyway and tooth marked '0'

Note: Check for clearance between timing chain and oil gallery boss.

1. Disassemble the motor as recommended in the service manual to gain access to the timing gear.
2. Fit new timing gear set to the engine as illustrated.
3. Fit the oil pump drive to the crankshaft.

Lubrication: For maximum chain life proper chain lubrication is necessary. When RPM increases chain lubrication must also increase. In order to reduce wear, a good lubricant must form a film over the contacting surfaces. Excessive wear can cause the chain to lengthen to the point of damaging sprocket teeth and destroying the chain.

Warning: Do not use the keyway marks to time engine. Always align the crank gear tooth timing mark to cam gear timing mark.

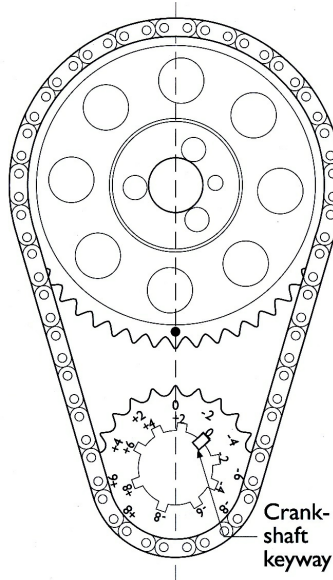

2 Advanced Timing

(+2° +4° +6° +8°)

1. Before assembly carefully inspect the crankshaft sprocket. Note the position of each keyway on the inside diameter and the position of the equivalent timing mark on the outside gear tooth.
2. Fit the crankshaft sprocket to the crankshaft, ensuring that the keyway selected is aligned to the crankshaft keyway.
3. Rotate the crankshaft until the selected advance position on the outer sprocket is aligned with the timing mark on the camshaft sprocket.

We recommend using a good service manual when installing new componentry.

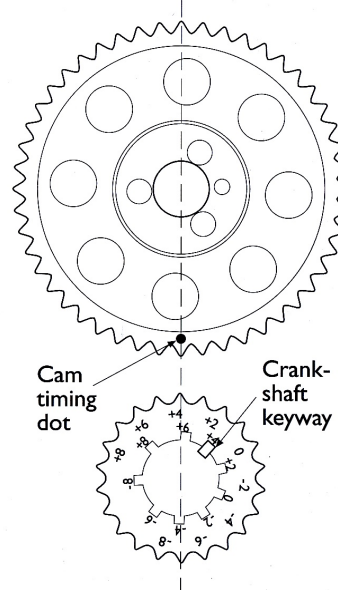

3 Retard Timing

(-2° -4° -6° -8°)

1. Before assembly carefully inspect the crankshaft sprocket. Note the position of each keyway on the inside diameter and the position of the equivalent timing mark on the outside gear tooth.
2. Fit the crankshaft sprocket to the crankshaft, ensuring that the keyway selected is aligned to the crankshaft keyway.
3. Rotate the crankshaft until the selected retard position on the outer sprocket is aligned with the timing mark on the camshaft sprocket.

We recommend to always degree-in the camshaft before making any timing changes. Use JP5720 degree wheel.

